

# Type 4X Fiberglass Enclosures

## Wall-Mount Enclosures Type 4X Single-Door Data Sheet



### Application

- Houses electrical, electronic, instrument, and mechanical controls
- Intended for indoor or outdoor use
- Ideally suited for harsh environments
- Protects against corrosion, windblown dust and rain, splashing water, and hose directed water

### Standards

- UL/cUL 50 Listed, Type 1, Type 3, Type 3R, Type 4X, Type 12
- Conforms to NEMA Standard for Type 1, Type 3, Type 3R, Type 4X, Type 12
- CSA 22.2, Type 1, Type 3, Type 3R, Type 4X, Type 12
- Temperature Range: -40°F to 250°F (-40°C to 120°C)
- Flammability Rating: UL94-5V
- Self Extinguishing: Non-flame propagating
- Chemical Resistance: (see chart, pages 458 - 461)

### Finish

- Gray color

### Accessories

- Back Panels (pages 290 - 291)
- See accessories (pages 292 - 293)

### Construction

- Enclosures are an impact resistant, non-conductive, light-weight hot compression molded fiberglass reinforced polyester
- Poured polyurethane seamless gasket provides watertight, dust-tight environmental seal
- Twist lock latches provide ease of entry into enclosure
- 300 series stainless steel used on all external hardware
- Integral mounting feet molded in place for ease of mounting
- Integral mounting bosses utilize threaded brass inserts accepting #10-32 screws for mounting optional panel
- Rounded edges reduce build-up of dust and debris
- Full length stainless steel hinged cover
- Built in padlock hasp provide optional secure closure locking (padlock not included)

### Discount Schedule: F2

### Subclass: G00

**Notes:** Cooper B-Line can provide special modifications. Consult the factory for your special requirements.

# Type 4X Fiberglass Enclosures

## Wall-Mount Enclosures Type 4X Single-Door Illustration Sheet and Catalog Number

Enclosure Catalog #	Overall Dimensions		Inside Dimensions		Dimensions												Panel Number		
	H x W x D		A x B x C		E		F		J		K		L		M			N	
	in.	mm	in.	mm	in.	mm	in.	mm	in.	mm	in.	mm	in.	mm	in.	mm		in.	mm
201612-4XF	22.75 x 16.87 x 13.77	578 x 429 x 350	19.70 x 16.04 x 13.24	500 x 407 x 336	21.50	546	10.12	257	12.26	312	15.25	387	11.25	286	16.75	425	12.19	310	AWF2016__
24126-4XF	26.95 x 13.72 x 7.98	685 x 348 x 203	24.00 x 12.87 x 7.33	610 x 327 x 186	25.75	654	6.25	159	6.33	161	19.25	489	7.25	184	21.00	533	8.37	213	AWF2412__
241210-4XF	26.95 x 13.72 x 11.99	685 x 348 x 304	24.00 x 12.87 x 11.33	610 x 327 x 288	25.75	654	6.25	159	10.33	262	19.25	489	7.25	184	21.00	533	8.37	213	AWF2412__
24208-4XF	27.00 x 21.24 x 9.90	686 x 539 x 252	24.05 x 20.39 x 9.25	611 x 518 x 235	25.75	654	14.00	356	8.25	209	19.25	489	15.25	387	21.25	540	16.00	406	AWF2420__
242410-4XF	27.00 x 25.24 x 11.90	686 x 641 x 302	24.05 x 24.39 x 11.25	611 x 619 x 286	25.75	654	17.87	454	10.25	260	19.25	489	19.25	489	21.25	540	20.00	508	AWF2424__
242412-4XF	27.00 x 25.24 x 13.90	686 x 641 x 353	24.05 x 24.39 x 13.25	611 x 619 x 336	25.75	654	17.87	454	12.25	311	19.25	489	19.25	489	21.25	540	20.00	508	AWF2424__
30206-4XF	32.86 x 20.99 x 7.89	835 x 533 x 200	29.90 x 20.14 x 7.23	760 x 511 x 184	31.75	806	14.25	362	6.23	158	25.25	641	15.25	387	27.00	686	16.50	419	AWF3020__
30208-4XF	32.86 x 20.99 x 9.89	835 x 533 x 251	29.90 x 20.14 x 9.23	760 x 511 x 234	31.75	806	14.25	362	8.23	209	25.25	641	15.25	387	27.00	686	16.50	419	AWF3020__
302010-4XF	32.86 x 20.99 x 11.89	835 x 533 x 302	29.90 x 20.14 x 11.23	760 x 511 x 285	31.75	806	14.25	362	10.23	260	25.25	641	15.25	387	27.00	686	16.50	419	AWF3020__
302012-4XF	32.86 x 20.99 x 13.89	835 x 533 x 353	29.90 x 20.14 x 13.23	760 x 511 x 336	31.75	806	14.25	362	12.23	311	25.25	641	15.25	387	27.00	686	16.50	419	AWF3020__
30248-4XF	33.41 x 26.32 x 8.81	849 x 668 x 224	30.46 x 25.47 x 8.12	774 x 647 x 206	32.25	819	18.50	470	7.12	181	25.25	641	19.25	489	27.38	695	21.25	540	AWF3024__
302410-4XF	33.41 x 26.32 x 11.95	849 x 668 x 304	30.46 x 25.47 x 11.27	774 x 647 x 286	32.25	819	18.50	470	10.27	261	25.25	641	19.25	489	27.38	695	21.25	540	AWF3024__
302412-4XF	33.41 x 26.32 x 13.79	849 x 668 x 350	30.46 x 25.47 x 13.10	774 x 647 x 333	32.25	819	18.50	470	12.10	307	25.25	641	19.25	489	27.38	695	21.25	540	AWF3024__
36308-4XF	39.31 x 32.50 x 10.05	999 x 826 x 255	36.31 x 31.69 x 9.36	922 x 805 x 238	38.13	968	23.88	606	8.36	212	31.25	794	25.25	641	33.25	845	27.25	692	AWF3630__
363010-4XF	39.31 x 32.50 x 12.05	999 x 826 x 306	36.31 x 31.69 x 11.36	922 x 805 x 289	38.13	968	23.88	606	10.36	263	31.25	794	25.25	641	33.25	845	27.25	692	AWF3630__
363012-4XF	39.31 x 32.50 x 14.05	999 x 826 x 357	36.31 x 31.69 x 13.36	922 x 805 x 339	38.13	968	23.88	606	12.36	314	31.25	794	25.25	641	33.25	845	27.25	692	AWF3630__
483612-4XF	51.29 x 36.62 x 13.79	1303 x 930 x 350	48.33 x 36.22 x 13.25	1228 x 920 x 336	50.12	1273	28.50	724	12.25	311	21.63	549	31.25	794	45.25	1149	32.00	813	AWF4836__
483616-4XF	51.29 x 36.62 x 17.79	1303 x 930 x 452	48.33 x 36.22 x 17.25	1228 x 920 x 438	50.12	1273	28.50	724	16.25	413	21.63	549	31.25	794	45.25	1149	32.00	813	AWF4836__
603612-4XF	64.00 x 36.50 x 14.12	1627 x 927 x 359	60.62 x 36.13 x 13.44	1540 x 918 x 341	62.75	1594	28.75	730	12.44	316	27.63	702	31.25	794	57.25	1454	32.00	813	AWF6036__
603616-4XF	64.00 x 36.50 x 18.12	1627 x 927 x 460	60.62 x 36.13 x 17.44	1540 x 918 x 442	62.75	1594	28.75	730	16.44	418	27.63	702	31.25	794	57.25	1454	32.00	813	AWF6036__

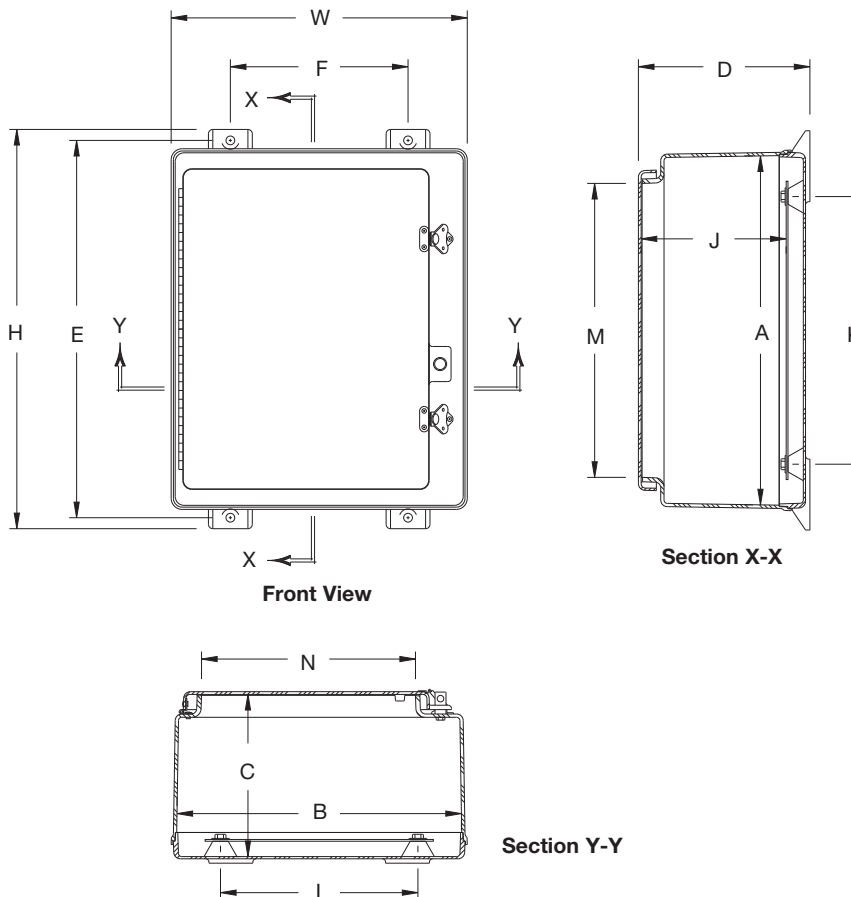

### Panel Finishes

Example: AW108\_\_

Insert for \_\_

P = Carbon Steel  
SP = Stainless Steel  
AP = Aluminum

Notes: Dimensions are in inches. Millimeters shown are for reference only. Data subject to change without notice.